

CZ BC FW150L/SW150L

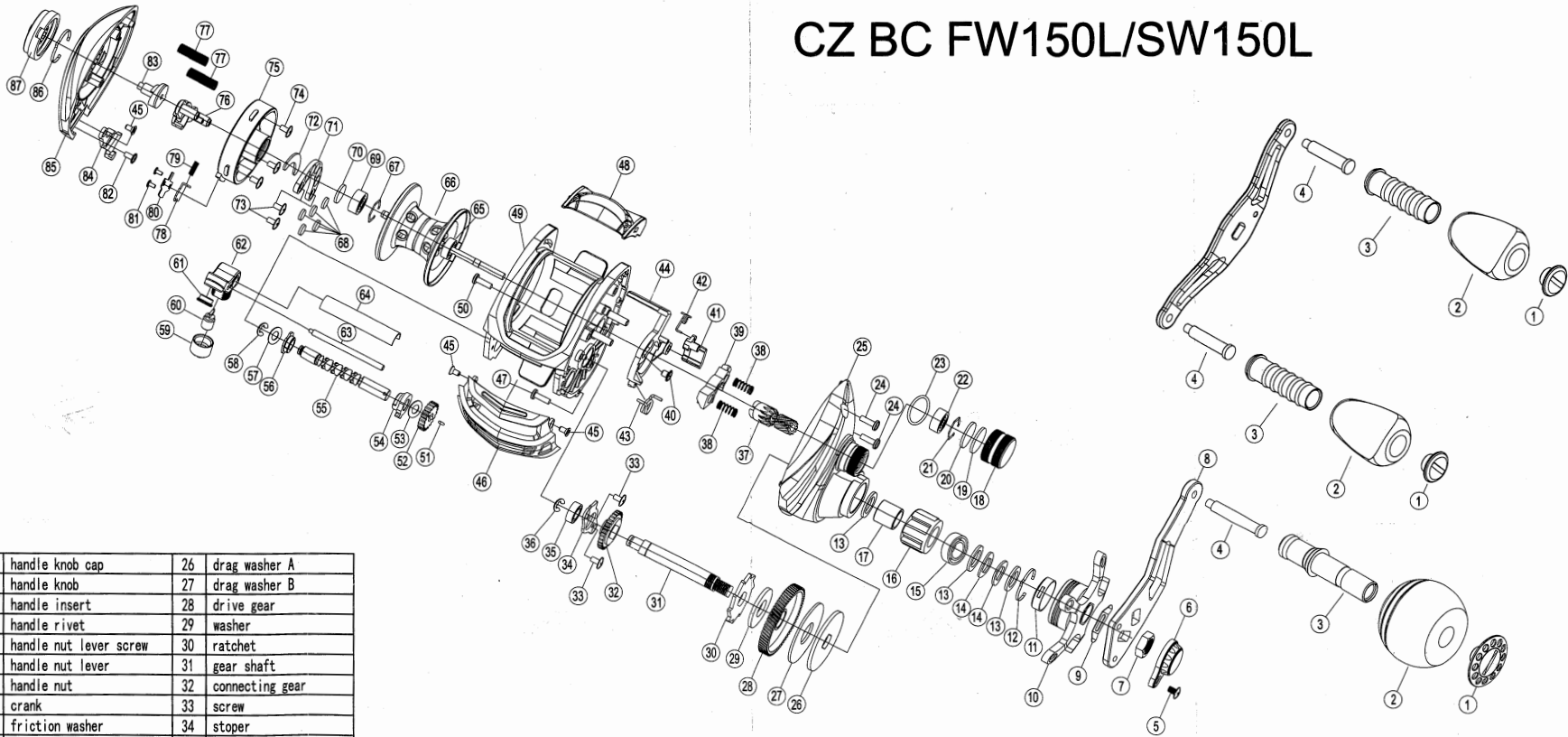

1	handle knob cap	26	drag washer A
2	handle knob	27	drag washer B
3	handle insert	28	drive gear
4	handle rivet	29	washer
5	handle nut lever screw	30	ratchet
6	handle nut lever	31	gear shaft
7	handle nut	32	connecting gear
8	crank	33	screw
9	friction washer	34	stopper
10	star handle assembly	35	ball bearing
11	click holder	36	E-ring
12	click spring	37	pinion gear
13	drag spring washer	38	clutch spring
14	bridge washer	39	clutch
15	ball bearing	40	screw
16	one way clutch	41	kick lever
17	one way collar	42	kick lever spring
18	control cap	43	clutch spring
19	cushion rubber	44	clutch cam
20	brake washer	45	front cover screw
21	stopper spring	46	front cover
22	ball bearing	47	screw B
23	O-ring	48	clutch lever
24	screw A	49	frame
25	cover A	50	screw C
26	drag washer A	51	carriage screw pin
27	drag washer B	52	carriage screw gear
28	drive gear	53	washer
29	washer	54	guide bushing-B
30	ratchet	55	carriage screw
31	gear shaft	56	guide bushing-A
32	connecting gear	57	washer
33	screw	58	E-ring
34	stopper	59	pawl cap
35	ball bearing	60	return pawl
36	E-ring	61	guide ring
37	pinion gear	62	line guide holder
38	clutch spring	63	holder guide
39	clutch	64	stabilizer bar
40	screw	65	ball bearing
41	kick lever	66	spool assembly
42	kick lever spring	67	stopper spring
43	clutch spring	68	magnet
44	clutch cam	69	ball bearing
45	front cover screw	70	brake washer
46	front cover	71	magnet holder
47	screw B	72	magnet plate
48	clutch lever	73	screw
49	frame	74	screw
50	screw C	75	spool cover
51	carriage screw pin	76	brake cam plate
52	carriage screw gear	77	spring
53	washer	78	spring plate
54	guide bushing-B	79	spring
55	carriage screw	80	lockcover
56	guide bushing-A	81	screw
57	washer	82	screw
58	E-ring	83	brake cam
59	pawl cap	84	key push lever
60	return pawl	85	cover B
61	guide ring	86	click spring
62	line guide holder	87	brake control lever